

THIS DRAWING IS UNPUBLISHED. RELEASED FOR PUBLICATION  
 © COPYRIGHT - By - ALL RIGHTS RESERVED.

LOC		DIST		REVISIONS			
P	LTR	DESCRIPTION		DATE	DWN	APVD	
FT	47	S1	REVISED PER ECO-14-001675		05FEB2014	NK	MZ

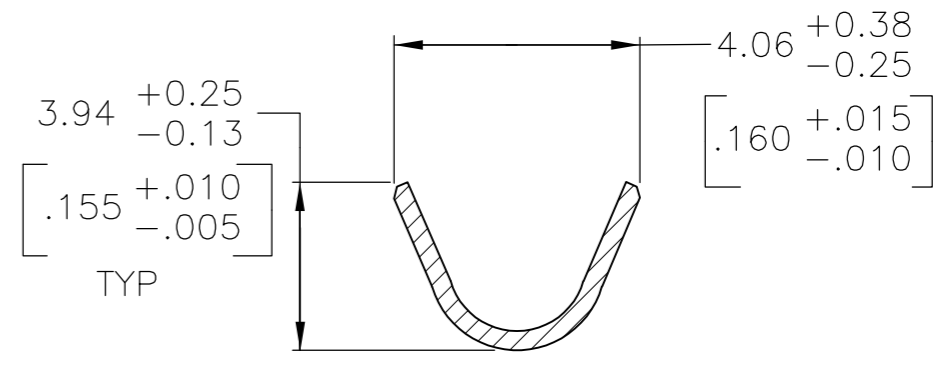

SECTION A-A

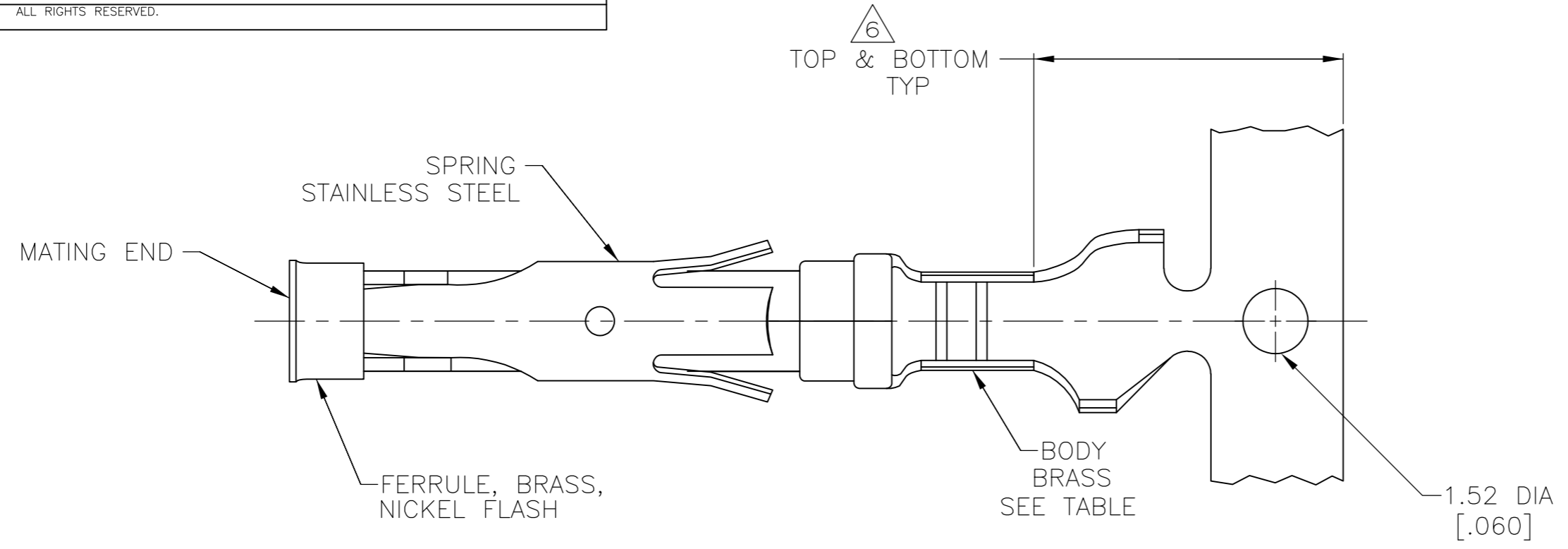
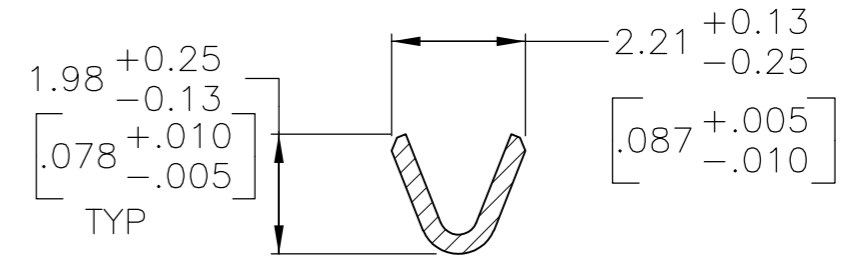
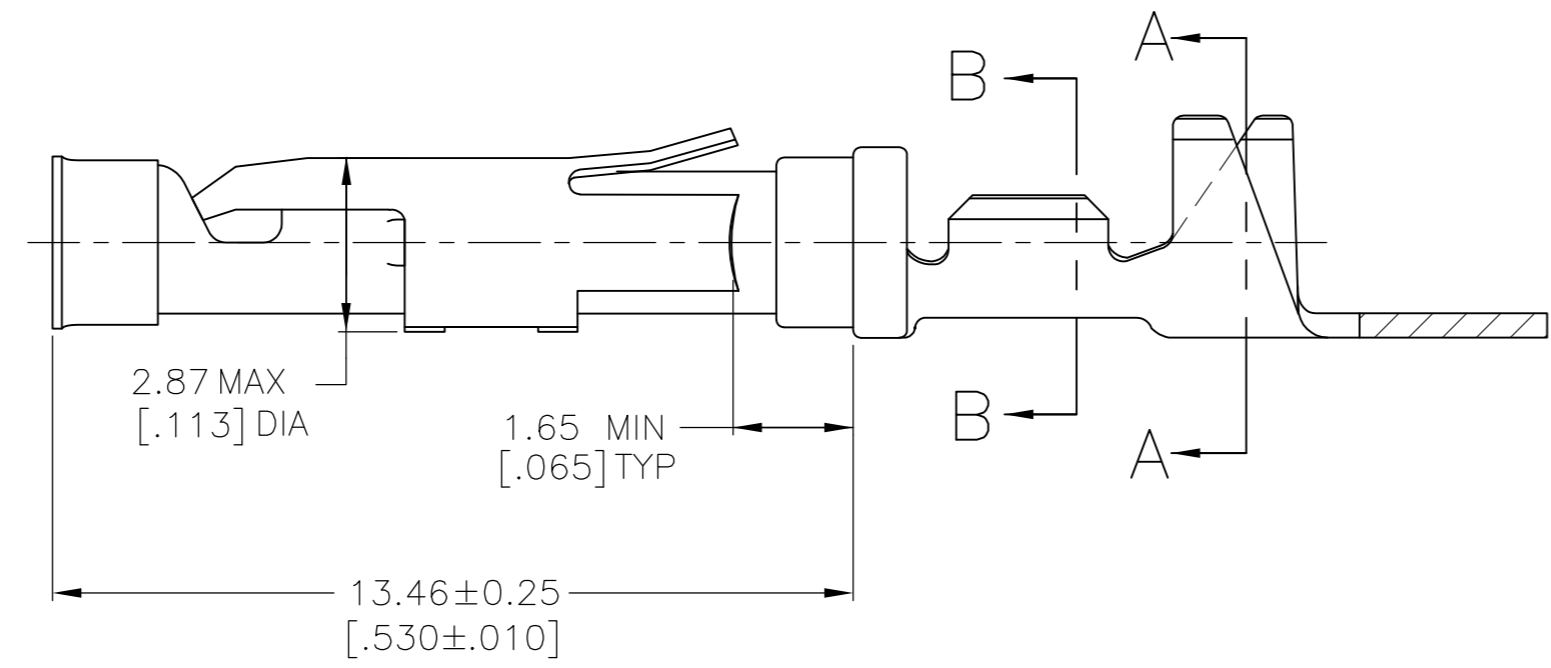
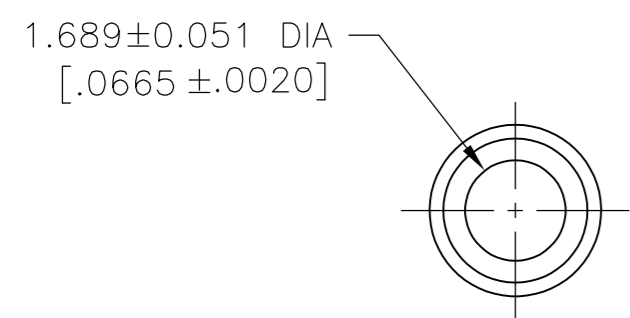

SECTION B-B

- 1 0.76µm [.000030] MIN GOLD PER MIL-G-45204 ON MATING END FOR A LENGTH OF 5.08 [.200] MIN WITH 1.27µm [.000050] MIN MATTE TIN PLATE IN WIRE CRIMP AREA, BOTH OVER 0.76µm [.000030] MIN NICKEL PER QQ-N-290.
- 2 1.27µm [.000050] MIN TIN-LEAD PER MIL-T-10727 OVER 0.76µm [.000030] MIN NICKEL PER QQ-N-290.
- 3 0.76µm [.000030] MIN GOLD PER MIL-G-45204 ON MATING END FOR A LENGTH OF 5.08 [.200] MIN WITH A UNIFORM GRADIENT TO 0.25µm [.000010] MIN GOLD PER MIL-G-45204 ON THE REMAINDER OVER 0.76µm [.000030] MIN NICKEL PER QQ-N-290.
- 4 0.38µm [.000015] MIN GOLD PER MIL-G-45204 ON MATING END FOR A LENGTH OF 5.08 [.200] MIN WITH GOLD FLASH ON THE REMAINDER OVER 0.76µm [.000030] MIN NICKEL PER QQ-N-290.
- 5 1.27µm [.000050] MIN GOLD PER MIL-G-45204 ON MATING END FOR A LENGTH OF 5.08 [.200] MIN WITH GOLD FLASH ON REMAINDER OVER 3.81µm [.000150] MIN NICKEL PER QQ-N-290.
- 6 GOLD PLATING NEED NOT APPEAR IN THIS AREA.
- 7 REVERSE REELED FOR MINI-APPLICATOR.
- 8 WIRE RANGE 24-20 AWG. INSULATION RANGE 1.52[.060]-3.05[.120].
- 9 0.38µm [.000015] MIN GOLD PER MIL-G-45204 ON MATING END FOR A LENGTH OF 5.08 [.200] MIN, 1.27µm [.000050] MIN TIN-LEAD PER MIL-T-10727 FOR A LENGTH OF 5.69 [.224] MIN ON OPPOSITE END, BOTH OVER 1.27µm [.000050] MIN NICKEL PER QQ-N-290 ON ENTIRE CONTACT.

10 1.27µm [.000050] MIN TIN PER MIL-T-10727 OVER 0.76µm [.000030] MIN NICKEL PER QQ-N-290.

	66565-7	7	10	1-66563-1
OBSOLETE	66565-5	7	9	1-66563-0
OBSOLETE	-	7	5	66563-9
	66565-4	7	1	66563-8
	66565-3	7	4	66563-7
	66565-2	7	2	66563-6
	66565-1	7	3	66563-5
	66565-4	STANDARD	1	66563-4
	66565-1	STANDARD	3	66563-1
LOOSE PIECE REF		REELING	BODY FINISH	PART NO

THIS DRAWING IS A CONTROLLED DOCUMENT.		DWN	R.SHIREY	8-7-91		TE Connectivity						
DIMENSIONS: mm [INCHES]		CHK	R.STONE	9-19-91		NAME						
TOLERANCES UNLESS OTHERWISE SPECIFIED:		APVD	J.WESTMAN	9-20-91		SOCKET ASSEMBLY, .062, TYPE III+						
0 PLC ± - 1 PLC ± - 2 PLC ± 0.13 [.005] 3 PLC ± - 4 PLC ± - ANGLES ± - FINISH SEE CALLOUTS		PRODUCT SPEC	-			SIZE	A2	CAGE CODE	00779	DRAWING NO	C=66563	RESTRICTED TO
MATERIAL SEE CALLOUTS		WEIGHT	-		SCALE	8:1	SHEET	1 of 1	REV	S1	CUSTOMER DRAWING	